



Owner's Manual

LPR4500RB Hide-A-Way[®]

LPR45RBSR Hide-A-Way[®]

Trailer Rear Gate

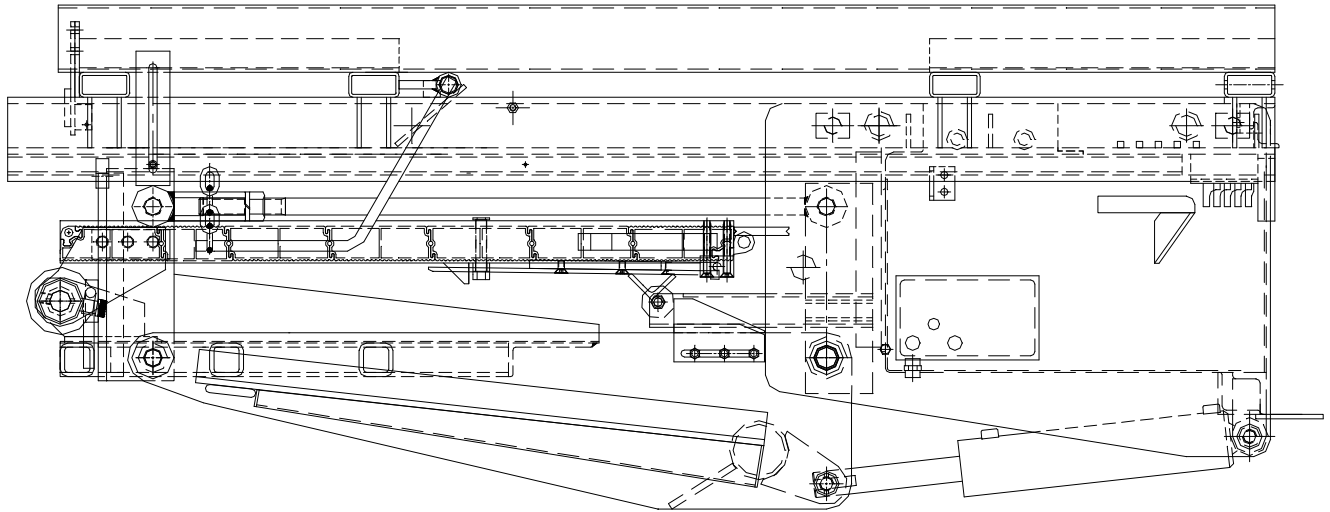

LEYMAN MANUFACTURING CORPORATION
10900 Kenwood Road
Cincinnati, OH 45242
1-866-LEYMAN-1 • 1-866-539-6261 • 513-891-6210
Fax 513-891-4901
www.leymanlift.com
sales@leymanlift.com

LML00446-12/5/12

TABLE OF CONTENTS

General Terminology	2
Lift Gate Operating Instructions	3
Operating the Emergency Hand Pump	4
General Specifications	5
Preventative Maintenance Schedule	6
Recommended Hydraulic Oils / Lubrication	7
Maintenance Minder 2®	8-10
Installation Adjustments	11-12
Troubleshooting Chart	13
Circuit Breaker Wiring Diagram	14
Wiring Diagram	15
Grounding Recommendations	16
Power Unit Replacement Parts	17
Hydraulic – Interior Replacement Parts	18
Hydraulic – Bottom Side Replacement Parts	19
Replacement Bearings, Shafts, and Misc.	20-21
Chain Area Replacement Parts	22
Emergency Hand Pump Parts (Optional)	23-24
Retention Ramp Parts	25-26
Side Ramp Parts (Optional)	27
Basic Electrics Replacement Parts	28
Std. Toggle Switch Replacement Parts	29
Toggle Switch w/ Pushbutton Repl. Parts	30
Installation of Safety Decals	31
Notes	32

GENERAL TERMINOLOGY

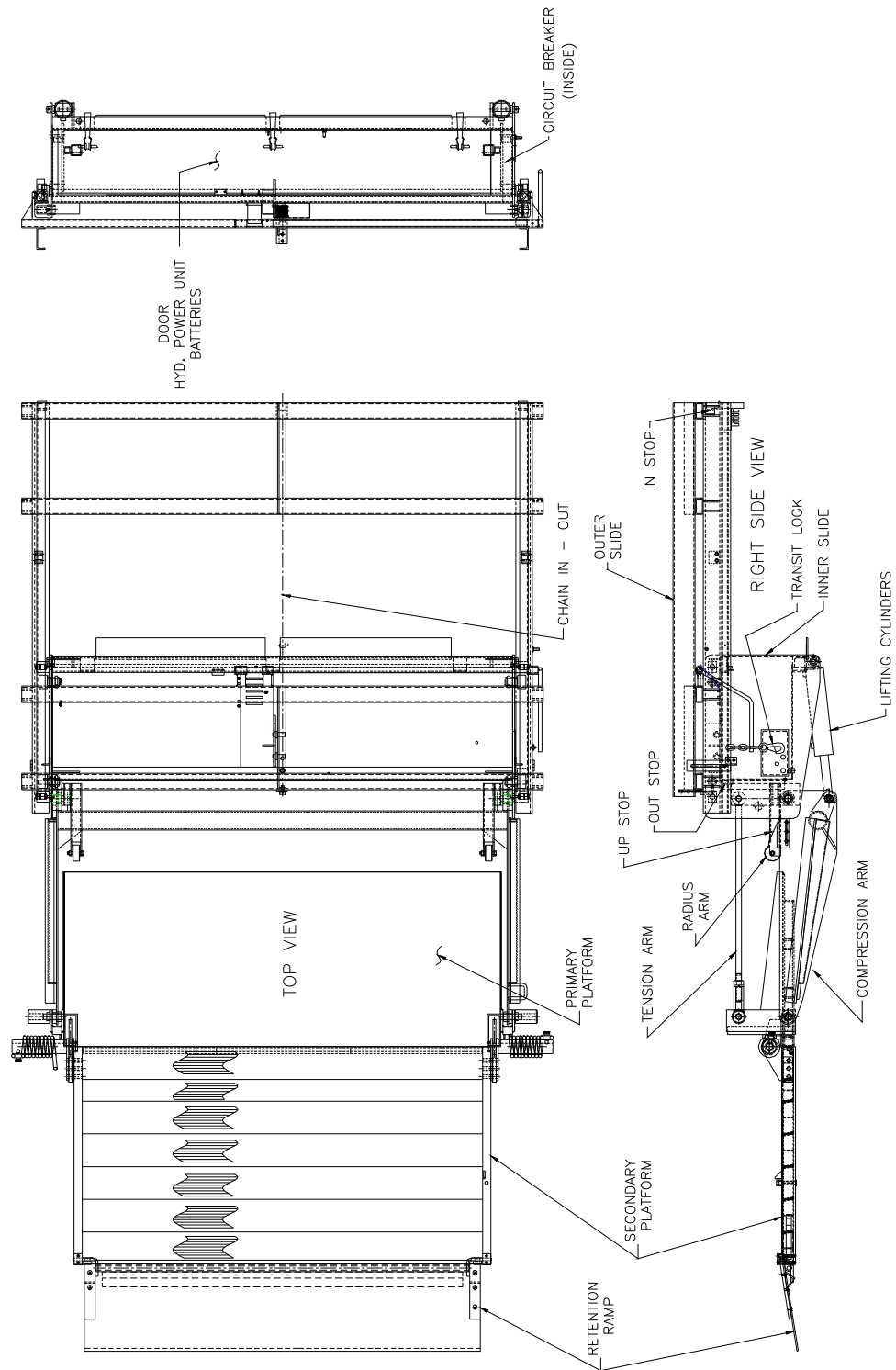

LIFT GATE OPERATING INSTRUCTIONS

DO NOT STAND BEHIND LIFT GATE WHILE UNFOLDING OR USING PLATFORM.

TO UNFOLD PLATFORM FROM OVER-THE-ROAD POSITION

1. TO RELIEVE TENSION ON SAFETY CHAIN, PUSH THE UP SWITCH. GATE WILL GO UP.
2. REMOVE SAFETY CHAIN FROM HOOK ON CURB SIDE OF LIFT.
3. USE DOWN SWITCH TO LOWER LIFT SEVERAL INCHES.
4. STAND TO SIDE OF LIFT GATE. PUSH THE IN / OUT SWITCH TO THE LEFT, AND GATE WILL RUN OUT. RUN GATE OUT UNTIL IT STOPS AND LOCKS IN ITS FULLY EXTENDED POSITION.
5. LOWER PLATFORM TO GROUND USING DOWN SWITCH. UNFOLD SECONDARY PLATFORM.

SAFE LOADING OF PLATFORM

1. RETENTION RAMP MUST BE SET VERTICAL WHENEVER LOADING PLATFORM FOR LOWERING, OR AFTER LOADING PLATFORM FOR LIFTING. SEE URGENT WARNING DECAL.

TO LOWER PLATFORM, USE THE DOWN SWITCH ONLY.

TO RAISE PLATFORM, USE THE UP SWITCH ONLY.

TO STORE GATE IN OVER-THE-ROAD POSITION:

1. POSITION PLATFORM NEAR GROUND. FOLD RETENTION RAMP AND LATCH
2. FOLD SECONDARY PLATFORM, THEN RAISE PLATFORM ONE FOOT OFF THE GROUND.
3. RAISE LOCK BAR HANDLE AND PUSH THE IN / OUT SWITCH TO THE RIGHT. RUN GATE ALL THE WAY UNDER TRAILER UNTIL LIFT STOPS.
4. RUN GATE UP. USE UP SWITCH.
5. HOOK SAFETY CHAIN ON CURB SIDE OF LIFT GATE.
6. LOWER GATE UNTIL CHAIN IS TIGHT. USE DOWN SWITCH.

P55438

OPERATING THE EMERGENCY HAND PUMP

If an emergency hand pump was supplied with this lift gate, its intended use is to restore the gate to the transit position.

CAUTION: *Do not* try to operate the power unit when using the hand pump.

Steps to secure the gate, so the trailer can be moved:

1. Access cover for Emergency Hand Pump is located on the driver's side of the lift gate. Loosen wing nuts and remove cover. If there is no access cover, or the cover is not removable, then the optional Emergency Hand Pump was not supplied.
2. Remove the pump handle from the holder and insert into the hand pump socket.
3. Raise the platform off the ground about 6". Pump side-to-side.
4. To retract the gate, disconnect the IN/OUT chain and manually push the gate under the trailer all the way until it stops.
5. Pump the gate until fully up. Then hook the Safety Chain on the curb side.
6. With the handle, unscrew the valve on the bottom of the hand pump. This will let the gate down so the Safety Chain is tight.

GENERAL SPECIFICATIONS

CUSTOMER:

MODEL: LPR

CAPACITY: 4500 lbs.

TYPE: Trailer Rear Door Lift Gate

HYDRAULIC PRESSURE: 2500 PSI – Up Function
800 PSI – In/Out Function

OPERATION: Power up/Gravity down
Power in/out

SERIAL #:

PREVENTATIVE MAINTENANCE SCHEDULE

MAINTENANCE by CYCLES

MODEL LPR4500RB

DATE: _____

CUSTOMER		GATE MODEL #	
LOCATION		GATE SERIAL #	
VEHICLE #		SERVICED BY	

√ = OK X = REPAIR A = ADJUSTED N = NOT APPLICABLE

3000	MOTOR / PUMP COMPONENTS	3000	MOTOR / PUMP COMPONENTS
	Check batteries for corroded, loose or broken connections		Check charge line/power line for corroded, loose or broken connections at both ends
	Check batteries for proper voltage level and charging		Check amp draw of motor with fully charged batteries and tight clean connections
	Check all wiring in pump box for corroded, loose or broken connections		Check all ground wires for corroded, loose or broken connections
	Check power unit solenoids for proper operation		Check pressure setting of relief valves
	Check reservoir for proper oil level (Gate down on the ground, fluid level should be 1" from top of tank)		Clean all wiring connections in pump and battery box. Spray with Fluid Film Corrosion Protection by Eureka. Use Color Guard or Liquid Electrical Tape on Start Solenoid.
	Inspect circuit breakers and fuses for proper operation		Check emergency hand pump for proper operation if equipped.
	Check all fittings/hoses in power unit for tightness and leaks		Check hydraulic motor sprockets for worn bushings and proper operation.

3000	STRUCTURAL COMPONENTS	3000	STRUCTURAL COMPONENTS
	Check for correct operation of the gate UP, DOWN, IN, and OUT.		Check IN/OUT chain for proper adjustment (no more than ½" play)
	Check wiring harness on side of gate for chaffed, frayed, or broken wires.		Check all pivot points for loose, broken, or missing roll pins
	Check wiring harness on side of gate for loose, broken, or missing clamps.		Check UP Stops for proper positioning of the platform and adjust as needed.
	Check the ground cable on side of gate for loose or corroded connections.		Check the OUT Stops for loose, broken, or missing hardware
	Check hydraulic cylinders for leaks		Check rollers for proper operation
	Check hydraulic cylinder pins for loose, broken, or missing roll pins.		Check over-all gate for damage or broken welds and repair as needed.
	Check Transit Position Safety Chain for proper operation. Snap Hook should latch, with no extra slack in chain.		Check Compression and Tension Arms for worn bushings
	Check all warning lights for proper operation if equipped		

3000	LUBRICATION		PERIODICAL CHECK LIST
	Stainless Steel Chain should not require any lubrication. Lubricate Idler Sprockets, Out Position Lock Shaft, Cam Rollers, and Cylinder Pins at base end.	12000	Check all pivot point bushings for wear or damage
		12000	Check hydraulic motor sprockets for worn bushings and proper operation.
		15000	Flush hydraulic system and change hydraulic oil
			Clean and repaint as necessary

MAINTENANCE MINDER ² READINGS MENU 2			
Screen 1 # Lifts	Screen 3 Service Faults	Screen 4 Low Voltage Faults	Screen 6 High Temperature Faults

TO RESET MAINTENANCE MINDER 2[®] after performing Preventative Maintenance. See page 8.

RECOMMENDED HYDRAULIC OILS/LUBRICATION

HYDRAULIC OILS	Manufacturer	Type	Temp. Range
Level 1 Normal Conditions	Mobile	DTE 11	-15° F to + 150° F
	Shell	TELLUS-T15	-15° F to + 150° F
	Exxon	UNIVIS-N15	-15° F to + 150° F
Level 2 Cold Conditions	Mobile	AERO-HFA	-50° F to + 80° F
	Shell	AERO FLUID#4	-50° F to + 80° F
	Exxon	UNIVIS-HVI13	-50° F to + 80° F
	Mil	H-5606	-50° F to + 80° F
HYDRAULIC TANK CAPACITY			
2 ½ gallons			
LUBRICATION	Cam Rollers, Idler Sprockets, Full-Out Position Lock shaft, Cylinder base pin		Lithium Base Grease
Grease			
BATTERIES			
Two (2) 12-Volt DC Group 31 Heavy-Duty Dual Purpose or AGM			
ELECTRICAL COMPONENTS CONNECTIONS			
Use Fluid Film Rust & Corrosion Protection by Eureka, except on Start Solenoid On Start Solenoid, use Color Guard by Loctite, or Liquid Electrical Tape			
AMPERAGE DRAW OF MOTOR			
When raising platform (empty) approximately 115 AMPS @ 13.5 volts. At bypass approximately 235 AMPS @ 13.5 volts			
LIFTING PRESSURE SETTING			
With platform at floor level and pump in bypass 2500 PSI			
IN-OUT PRESSURE SETTING			
When sliding gate in-out and pump in bypass 800 PSI			
MINIMUM VEHICLE FLOOR HEIGHT LADEN			
See LPR Installation manual			
MAXIMUM VEHICLE FLOOR HEIGHT UNLADEN			
See LPR Installation manual			
APPROXIMATE TIMES EMPTY AT 80° F WITH 2 GROUP 31 BATTERIES			
Time up: 14 – 18 seconds Time down(gravity down): 12 –16 seconds			

MAINTENANCE MINDER 2[®] OVERVIEW

Power unit is equipped with the Maintenance Minder 2[®] Controller. It will:

- Automatically keep track of maintenance intervals and warn the user when maintenance is due, based on the number of lifts.
- Record low voltage occurrences.
- Record of high temperature faults.
- Record of maximum run time faults, when a single operation exceeded the maximum continuous run time limit.
- Give helpful trouble-shooting information on MENU 4, “Last Lift Info”.

FAULTS CODES

A decal in the power unit enclosure lists the following signal codes for these faults:

1 BEEP	Service Fault (reached the number of lifts when maintenance is due)
2 BEEPS	Low Voltage Fault (check battery condition and power line connections)
3 BEEPS	Max. Time Fault (exceeded the maximum continuous run time allowed)
4 BEEPS	High Temperature Fault (unit will not run until motor cools)

All faults signals will be repeated FOUR times, except the Service Fault signal. Controller will prevent power unit from operating during the time period when a fault signal is sounding (about 5 to 10 sec.) except for the Service Fault signal. The controller is also equipped with an anti-doorbelling feature, which prevents rapid ON/OFF operation of the power unit.

RESETTING after MAINTENANCE IS PERFORMED

To RESET the Maintenance Minder 2[®] after maintenance has been performed:

1. Go to MENU 2, hit “ENTER”, and toggle down to the “Reset All Info” screen.
2. Press and hold the hidden RESET button under Maintenance Minder 2[®] logo at top of faceplate.
3. Follow the instructions on the screen regarding a second button, which must be pressed to complete the reset operation.



MAINTENANCE MINDER 2[®] CONTROLLER MENUS

(Press MENU)

MENU 1 – LIFT GATE INFO

(Press ENTER, then ARROW DOWN for each item)

Model Number, Serial Number, Manufacture Date, Vehicle ID, Hardware Version, Firmware Version, Software Version.



(Press MENU and ARROW DOWN once)

MENU 2 – PERIOD INFO (data for current maintenance period)

(Press ENTER, then ARROW DOWN for each item)

Number of Lifts (gives the number during this maintenance interval and the set number when maintenance is due)

Motor ON (total motor run time in minutes for this maintenance period)

Service Fault (number of times gate was operated PAST the maintenance limit)

Max. Time Faults (times motor exceeded its maximum allowable continuous run time)

High Temperature Faults (times thermal switch in motor tripped, if switch provided)

Low Voltage Faults (times low voltage occurred)

Reset all Info (Reset data after performing maintenance, once maintenance limit is reached – see reset instructions on previous page)



MAINTENANCE MINDER 2[®] CONTROLLER MENUS

(Press MENU and ARROW DOWN twice)

MENU 3 – LIFE TIME INFO (data for the total life time of the gate)

(Press ENTER, then ARROW DOWN for each item)

Same items will appear as under PERIOD INFO, except this is LIFE TIME data.

Reset History (reviews history for each maintenance interval)

Press ENTER, then ARROW DOWN to show history. Most recent period is the highest #. Screen shows Period #, # of Lifts, and Total Run Time in minutes.



(Press MENU and ARROW DOWN three times)

MENU 4 – LAST LIFT INFO (Trouble Shooting Screen – it records data that occurred during the last lift made)

(Press ENTER, then ARROW DOWN for each item)

Supply Voltage (first voltage is the minimum voltage that occurred during the last lift – if below 6 volts gate will stop / second voltage is the supply voltage just before gate operation, must be at least 10 volts).

Motor ON (motor run time in seconds during last lift, gate will stop at 180 seconds).

Window Time (time in milliseconds during the last lift that the voltage dropped in between 6 and 8 volts – must not be any longer than 3 seconds or gate will stop).



NOTE:

Controller has an anti-doorbelling feature. Motor will not operate if UP switch is toggled rapidly. This prevents welding of the start solenoid contacts.

INSTALLATION ADJUSTMENTS

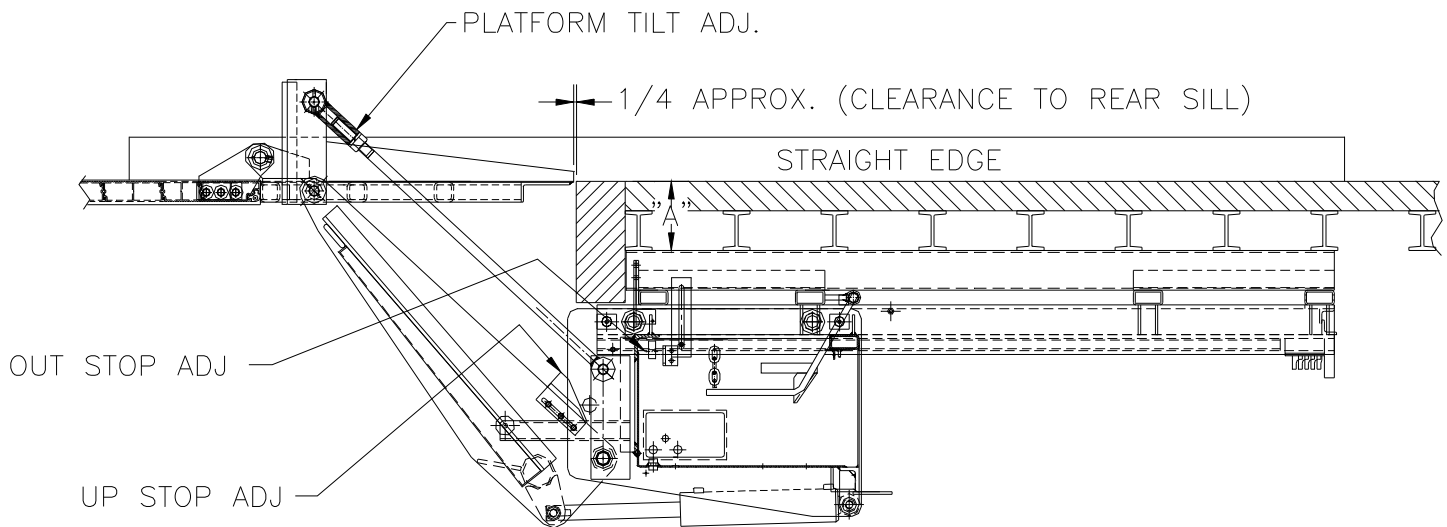

- Step 1: The platform was preset at the factory to be level to the floor of the trailer within 1/4". A slight slope toward the trailer is preferred over a slope away from the trailer. With a straight edge, check this. If it is okay, proceed to Step 2. If not, let the platform down to the ground. Remove the two (2) roll pins and the top Tension Arm pivot pins (one on each side). **NOTE:** One-half turn moves the tip of the platform 3/16" (turning the end in moves the retention ramp end of the platform up, unscrewing moves the retention ramp end of the platform down). Make necessary adjustments. Replace pins, raise the platform up and check. Repeat if necessary. Replace roll pins. **NOTE:** Each side must be adjusted the same amount.
- Step 2: Adjust the Up Stops. Platform should be even with the floor of the trailer. Tack weld.
- Step 3: Adjust the Out Stops (long set screws with locking nuts). The tip of the platform should be approximately 1/4" from the edge of the threshold.

INSTALLATION ADJUSTMENTS (Cont.)

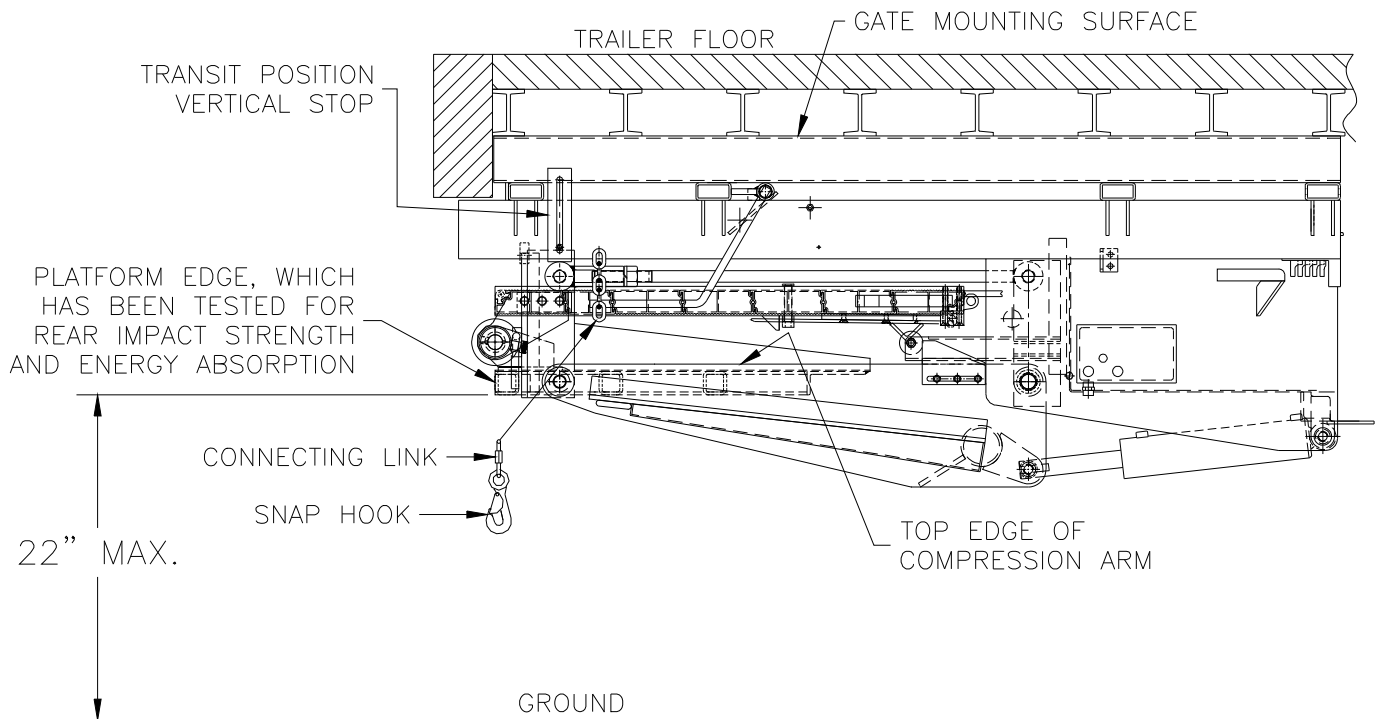

NOTE: A trailer with a rear mounted slider lift gate meets the definition of a “Special Purpose Vehicle”, and therefore is exempt from meeting FMVSS 223 and 224 Rear Impact Guard regulations. However, the LPR4500RB lift gate assembly has been tested and does meet all the strength and energy absorption requirements of FMVSS 223 (USA) and CMVSS 223 (Canada). To properly utilize this feature, the steel platform in the stored position must comply with the maximum height restriction (22”) for a Rear Impact Guard.

- Step 1:** If the Rear Impact Guard feature is to be utilized, adjust the Transit Position Vertical Stops on both sides such that the steel platform edge meets the 22” MAXIMUM dimension. If the Rear Impact Guard feature does NOT need to be utilized, adjust the Transit Position Vertical Stops on both sides so that the top edge of the Compression Arm is horizontal, with the gate powered UP against the Vertical Stops. This will give maximum ground clearance at the rear of the lift gate.
- Step 2:** Weld each Transit Position Stop in place with at least four (4) 3/16” fillet welds, 1” long.
- Step 3:** Adjust length of Safety Chain on curb side. With gate against Transit Position Vertical Stops, and Connecting Link and Snap Hook latched to loop on Compression Arm, determine the minimum number of chain links required. Remove excess links from the end of the chain, then attach Connecting Link and Snap Hook to the end of the chain.

TROUBLESHOOTING CHART

PROBLEM	PROBABLE CAUSE	REMEDY
The motor is running, but the platform will not go up or reach the floor of the vehicle.	<ol style="list-style-type: none"> 1. Insufficient oil in power unit tank. 2. Platform is over-loaded. 3. Pressure setting is low. 	<ol style="list-style-type: none"> 1. Fill tank to the appropriate level. 2. Load only to the rated capacity. Remove some product if necessary. 3. Check and adjust the pressure to the proper setting.
The platform will not go up or reach floor level and the motor does not run.	<ol style="list-style-type: none"> 1. Low battery. Check Maintenance Minder 2[®] for Low Voltage faults. 2. Tripped circuit breaker. 3. Power line is loose. 4. Bad motor, starter or switch 	<ol style="list-style-type: none"> 1. Recharge or replace battery. 2. Reset the circuit breaker. 3. Check the connections. If loose, tighten. Check for corrosion and clean if necessary. 4. To test-push the UP switch, if motor does not run, jump the two large terminals on the starter solenoid. The motor should run, if not, the motor is bad. If it does run, the solenoid is bad or is not getting a signal from the switch or the MM2. Use a test light to check.
Platform will not lower.	<ol style="list-style-type: none"> 1. Low battery. Need 10.5 volts to activate valve coils. 2. Bad ground or poor electrical connections. 3. Solenoid valve not opening. 4. Mechanical obstruction in gate. 	<ol style="list-style-type: none"> 1. Recharge or replace battery. 2. Check connections, if loose-tighten. Check for corrosion and clean if necessary. 3. Drain valve "C" valve (white wire) must activate when DOWN switch is pushed. Use test light to check. 4. Visually check.
Platform creeps down.	<ol style="list-style-type: none"> 1. Hydraulic leak. 2. Defective piston seal in cylinder. 3. "C" valve (white wire), or check valve not closing. 4. Drain valve at base of optional Hand Pump may be open. 	<ol style="list-style-type: none"> 1. Visually check for leaks. 2. Replace seals or cylinder. 3. Clean and inspect. 4. Check to see if valve on Hand Pump is closed tightly. Use end of Hand Pump handle.
Platform goes down slowly.	<ol style="list-style-type: none"> 1. Check for obstructions or damage to arms. 2. Restricted or pinched hydraulic lines. 3. "C" valve (white wire) not opening. 4. Incorrect hydraulic oil for cold weather operation 	<ol style="list-style-type: none"> 1. Visually check. 2. Check for bent or pinched lines. 3. Clean and inspect. 4. Use recommended hydraulic oils for conditions present.
Gate will not go OUT and/or IN.	<ol style="list-style-type: none"> 1. Check for obstructions in rails. 2. Low battery. Check Maintenance Minder 2[®] for Low Voltage faults. 3. Tripped circuit breaker. 4. Power line is loose. 5. Bad motor, starter or switch. 	<ol style="list-style-type: none"> 1. Visually check. Check Side Button adjustment 2. Recharge or replace battery. 3. Reset the circuit breaker. 4. Check the connections. If loose, tighten. Check for corrosion and clean if necessary. 5. To test: push OUT switch and motor does not run, jump the two large terminals on the starter solenoid. The motor should run, if it does not run, you have a bad motor. If it does run, the solenoid is bad or it is not getting a signal from the switch. Use test light to check (OUT is "A" valve "red wire", IN is "B" valve "orange wire").

CIRCUIT BREAKER WIRING DIAGRAM

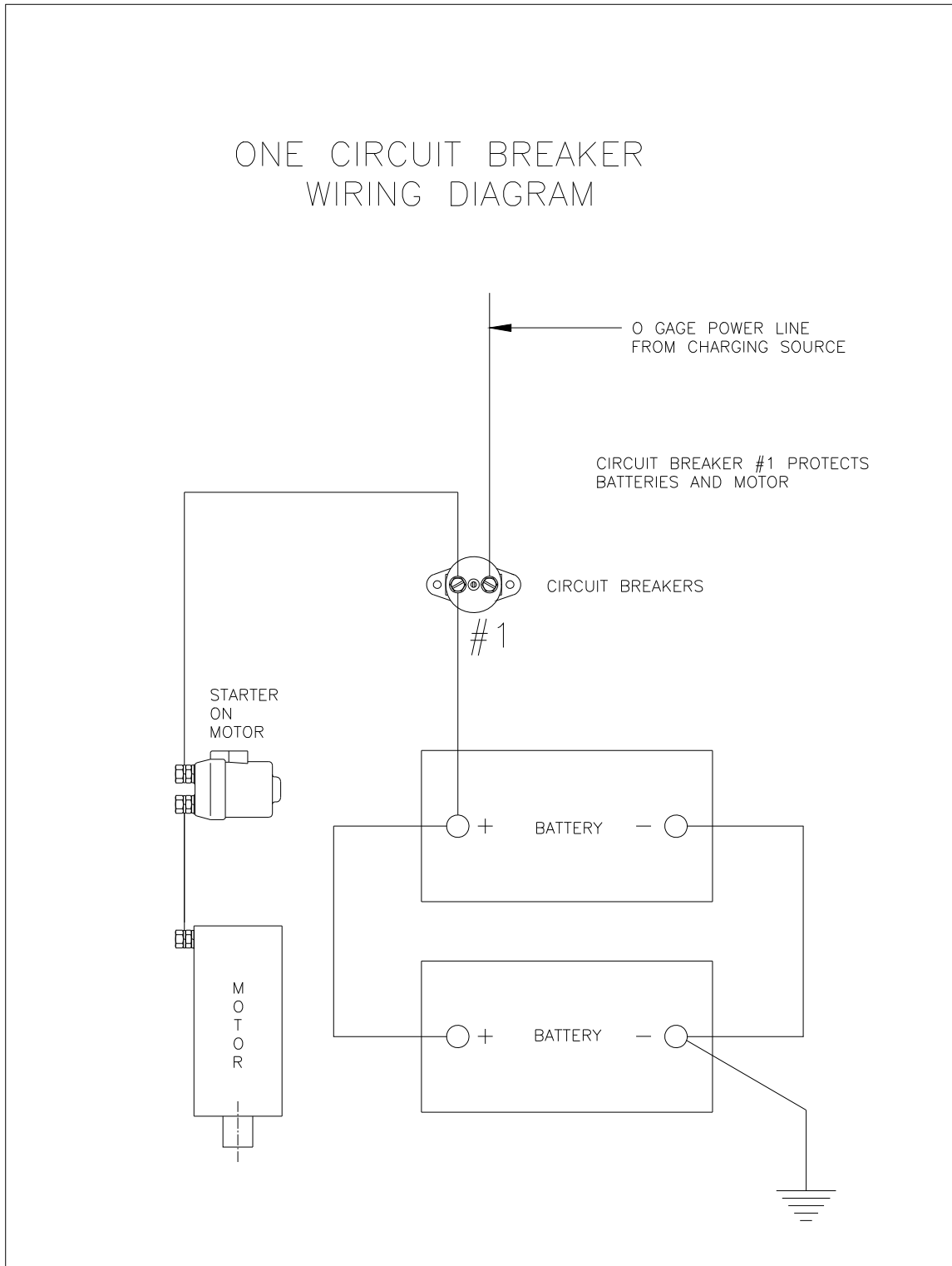

GROUNDING RECOMMENDATIONS

FOR TRACTOR/TRAILER USING MAINTENANCE MINDER 2[®] CONTROLLER

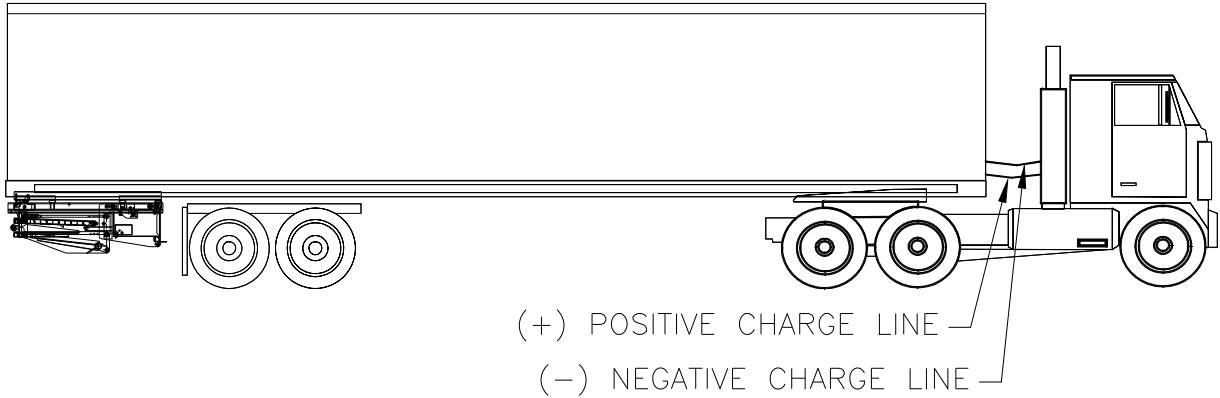

The Maintenance Minder 2[®] Controller requires a minimum of 10 volts to start and 8 volts to continue running the LPR lift gate. Power unit solenoid valves will require 10.5 volts to operate the coils. Utilization of a single positive cable often does not provide a sufficient ground for the charging circuit. Therefore, our recommendation for grounding tractor/trailers with the LPR gate is as follows:

Use two (2) cables, one (1) positive and one (1) negative, both running to the tractor batteries.

NOTE:

The use of a battery charger as the sole power source to operate a LPR is unauthorized and will prevent the LPR from working properly. The lift gate must always be operated in conjunction with at least one (1) 12 volt heavy-duty dual purpose or AGM lift gate battery. A minimum of 10.5 volts must be maintained in order for the valves to operate.

POWER UNIT REPLACEMENT PARTS

MONARCH POWER UNIT and MAINTENANCE MINDER 2

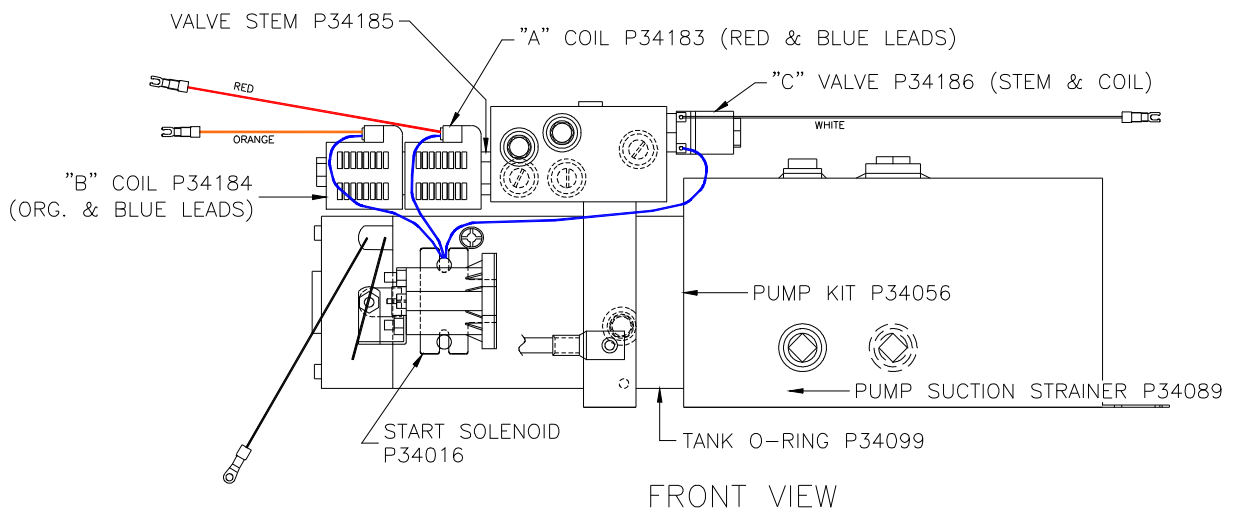
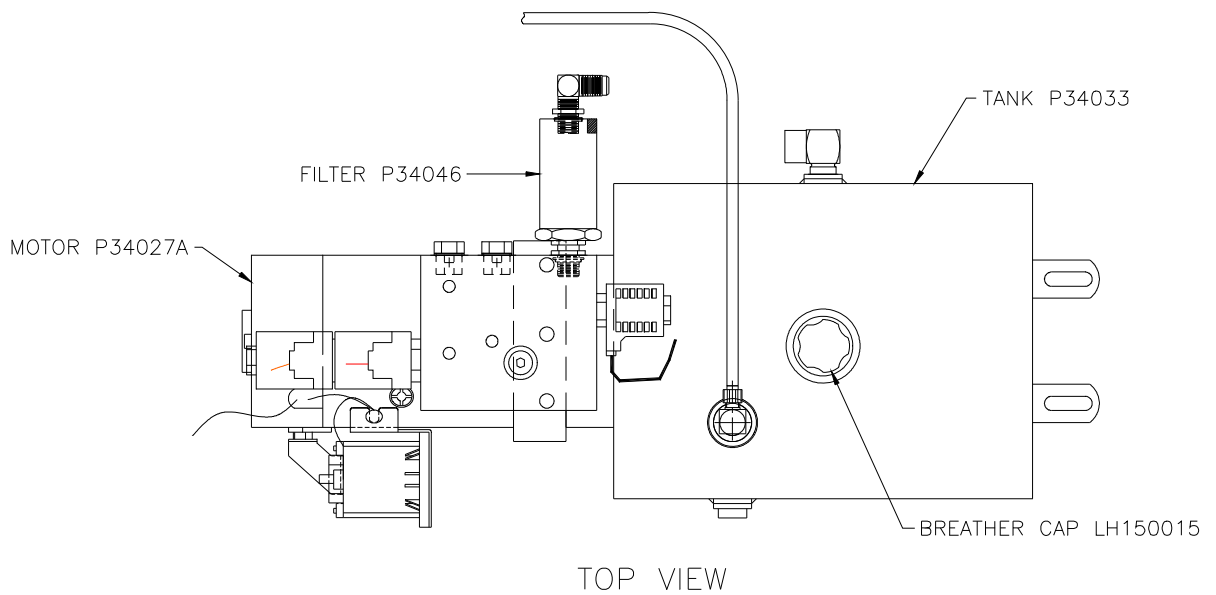

COMPLETE POWER UNIT (LESS FILTER AND FITTINGS) P34171
MAINTENANCE MINDER 2[®] CONTROLLER P46608H

HYDRAULIC - INTERIOR REPLACEMENT PARTS

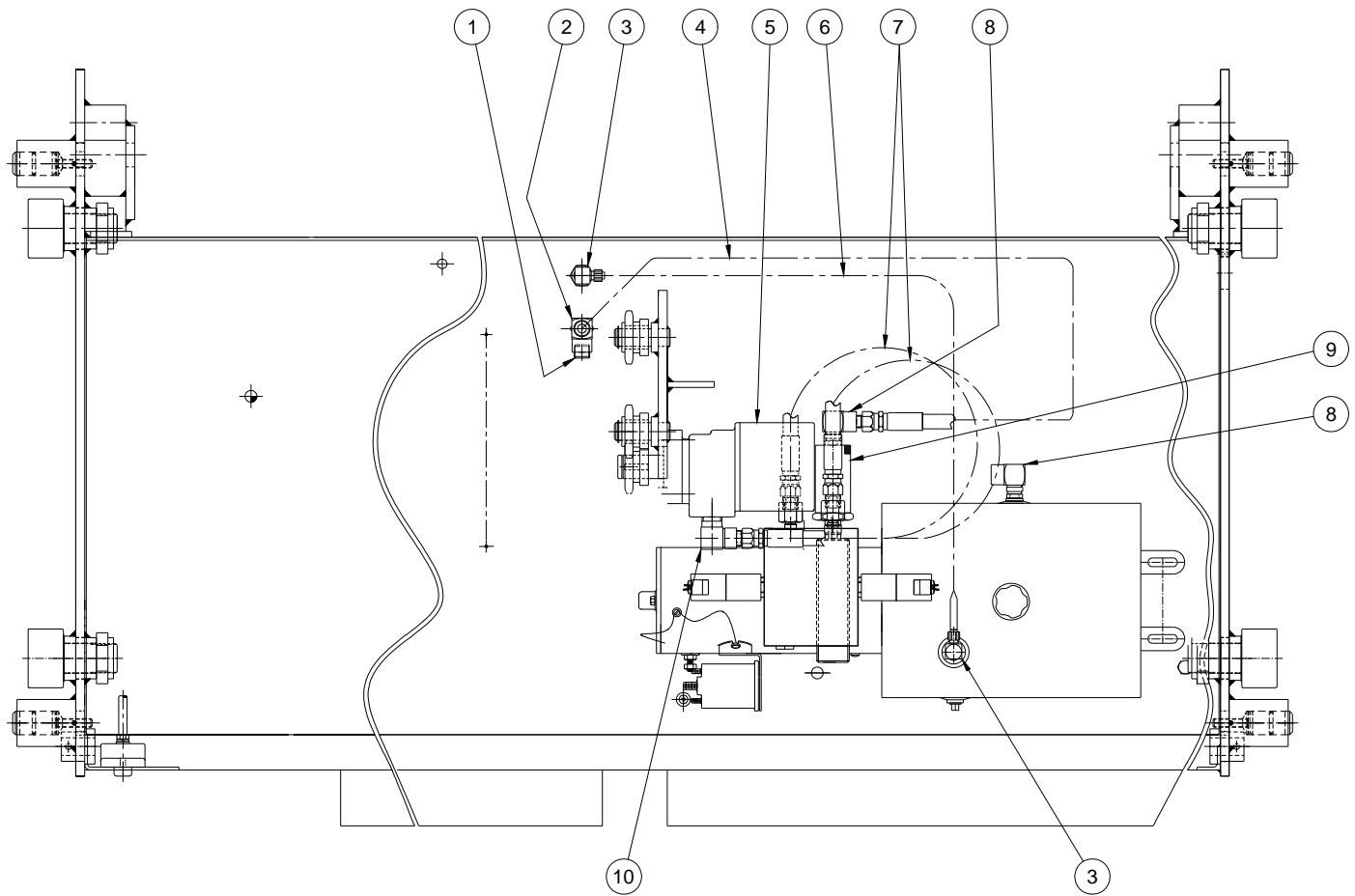

Index No.	Req'd	Part Number	Description	Comments
1	1	P34004	CAP NUT	JIC 9/16-18
2	1	P34048	TEE	JIC 9/16-18 M-M-F
3	2	P33932	BRASS MALE ELBOW	3/8NPT TO 1/4" HOSE
4	1	AT-501-354-027	HYDRAULIC HOSE	3/8 w/JIC ENDS
5	1	P33625	HYDRAULIC MOTOR	
6	1	P33702-026	1/4" POLY TUBE	
7	2	AT-501-292-020	HYDRAULIC HOSE	1/4 NPT - 3/8 NPT
8	2	P34020	ELBOW	SAE O-RING - JIC
9	1	P34046	INLINE FILTER	
10	2	P33202	STREET ELBOW	1/2(M) TO 3/8(F)

HYDRAULIC BOTTOM-SIDE REPLACEMENT PARTS

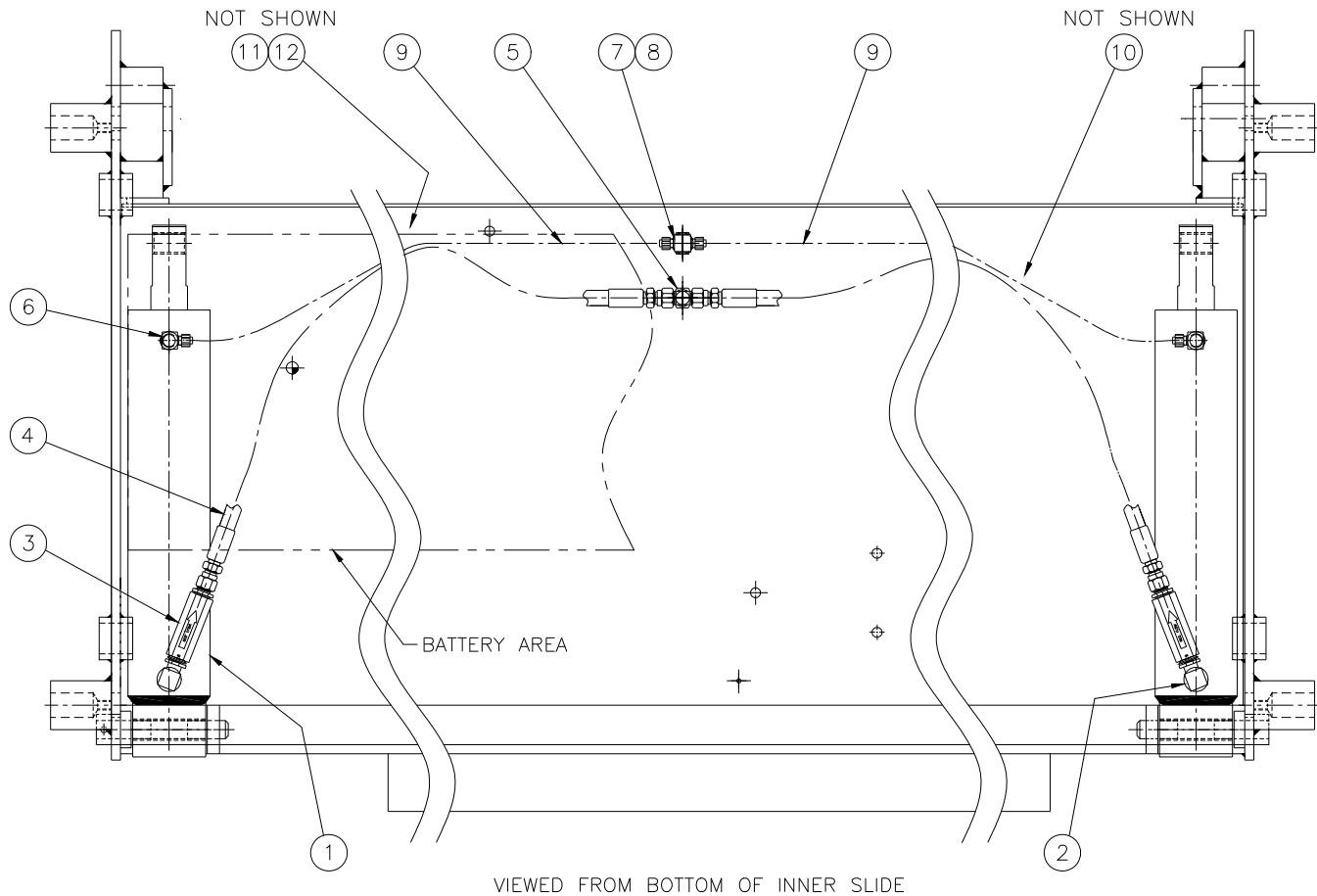

Index No.	Req'd	Part No.	Description	Comments
1	2	P34182	HYDRAULIC CYLINDER	3" BORE x 12" STROKE
2	2	P34041	MALE ELBOW	SAE O-RING (M) – SAE O-RING (M)
3	2	P34161	FLOW CONTROL	2.0 GPM
4	2	AT-501-354-044	HYDRAULIC LINE	
5	1	P34105	BULKHEAD TEE	
6	2	P33932	BRASS MALE ELBOW	
7	1	P33699	BRASS TEE	1/4 NPT TO 1/4 TUBE
8	1	P33617	REDUCER	3/8 NPT – 1/4 NPT
9	2	P33702-041	1/4 " POLY TUBE	
10	4	P46335	WIRE TIE	
11	2	P46251	LOOM CLAMP	
12	2	P17518	SELF-TAP SCREW	

REPLACEMENT BEARINGS, SHAFTS, MISC.

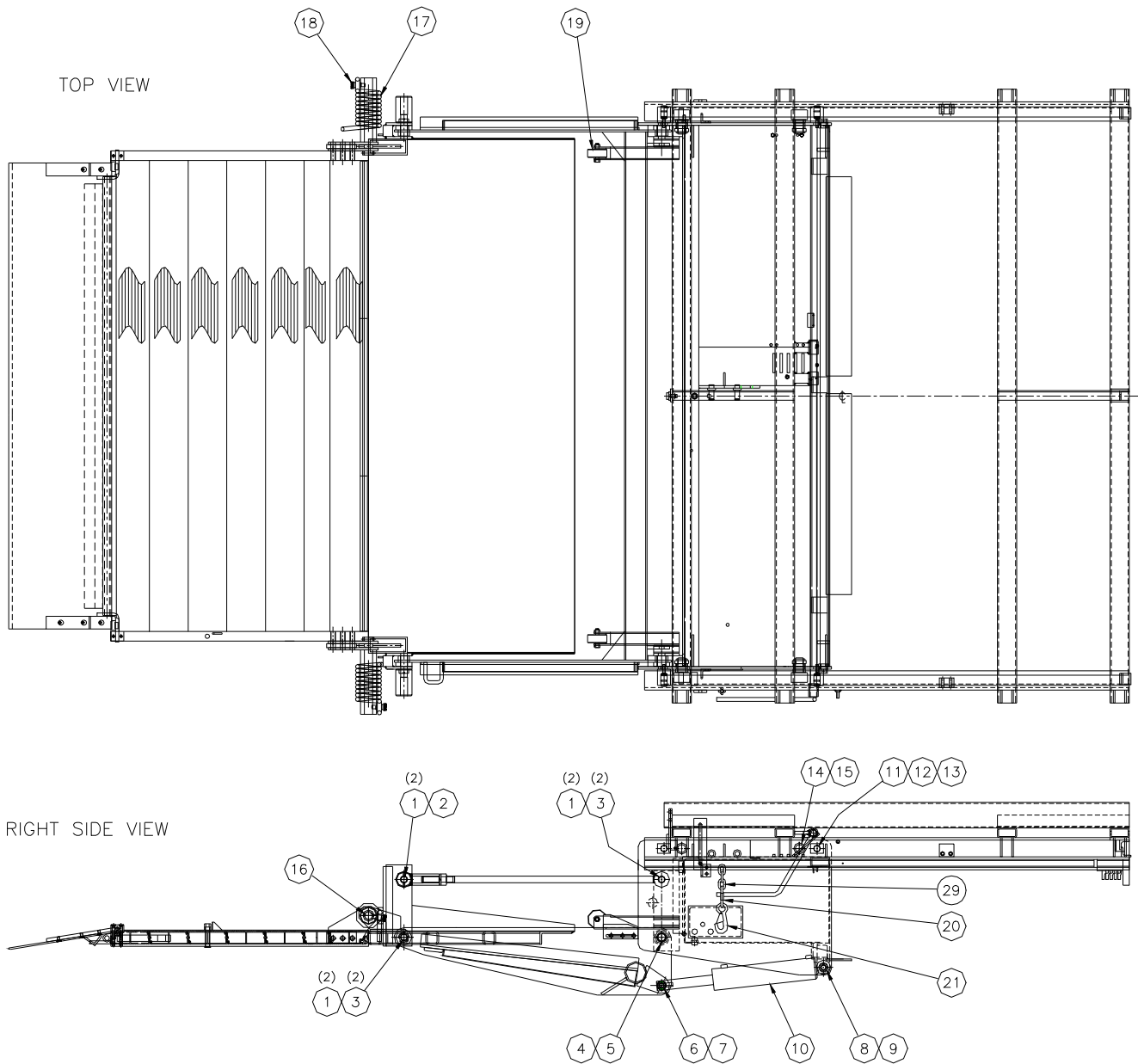

REPLACEMENT BEARINGS, SHAFTS, MISC. (Cont.)

Replacement Bearings, Shafts, Misc.					
Index #	Req'd	Part #	Part Name	Matl.	Matl. Size
1	6	P43567	Bearing		1 ID x 1-1/2 LG.
2	2	AP-817-582	Pin	CHR RD	1 DIA. x 7-5/8 LG.
3	4	AP-817-580	Pin	CHR RD	1 DIA x 3-1/4 LG.
4	2	P43566	Bearing		1-1/4 ID x 1-1/2 LG.
5	2	AP-817-579	Pin	CHR RD	1-1/4 DIA x 3-1/4 LG.
6	2	P43574	Bearing (Cyl. rod end)		3/4 ID x 1-1/4 LG.
7	2	AT-817-088-001	Pin	CHR RD	3/4 DIA x 3-3/8 LG.
8	4	P43573	Bearing (Cyl. base)		3/4 ID x 3/4 LG.
9	2	AT-817-088-002	Pin	CHR RD	3/4 DIA x 5-7/16 LG.
10	2	P34182	Hyd. Cylinder		3 Bore x 12 Stroke
11	4	AP-817-044	Side Skid Pad		1 OD x 1-13/16 LG.
12	4	P33925	O-Ring – Skid Pad		
13	4	AP-817-255	Disc – Skid Pad		15/16 OD
14	4	P37544	Cam Roller		One at each corner
15	4	P32012	Grease Fitting		At Cam Roller
16	2	AP-817-564	Pin	CR RD	1-1/4 DIA x 6 LG.
17	2	P25231	Torsion Spring		
18	2	P15548	Shoulder Screw		3/4 DIA x 1 w/ 5/8-11 Thrds.
19	2	P37553	Roller		At Radius Arm, 2" dia.
20	1	P33545	Rapid Connecting Link		
21	1	P33540	Safety Snap Hook		
22	8	P47514	Roll Pin 1/4 X 1-1/2	Not Shown	Use at Items 3, 7, 9
23	4	P47531	Roll Pin 1/4 X 1-3/4	Not Shown	Use at Items 5, 16
24	2	P47538	Roll Pin 1/4 X 2-1/2	Not Shown	Use at Items 2
25	2	P14519	Out Stop Set Screw	Not Shown	3/8-16 X 6 LG.
26	4	P22506	Out Stop Jam Nut	Not Shown	3/8-16
27	2	AP-817-592	Out Stop Angle	Not Shown	
28	7	P32016	Grease Fitting	Not Shown	At Out Stop Shaft, Cyl., Sprockets
29	18"	P38546	5/16 Transp. Chain		16 Links

CHAIN AREA REPLACEMENT PARTS

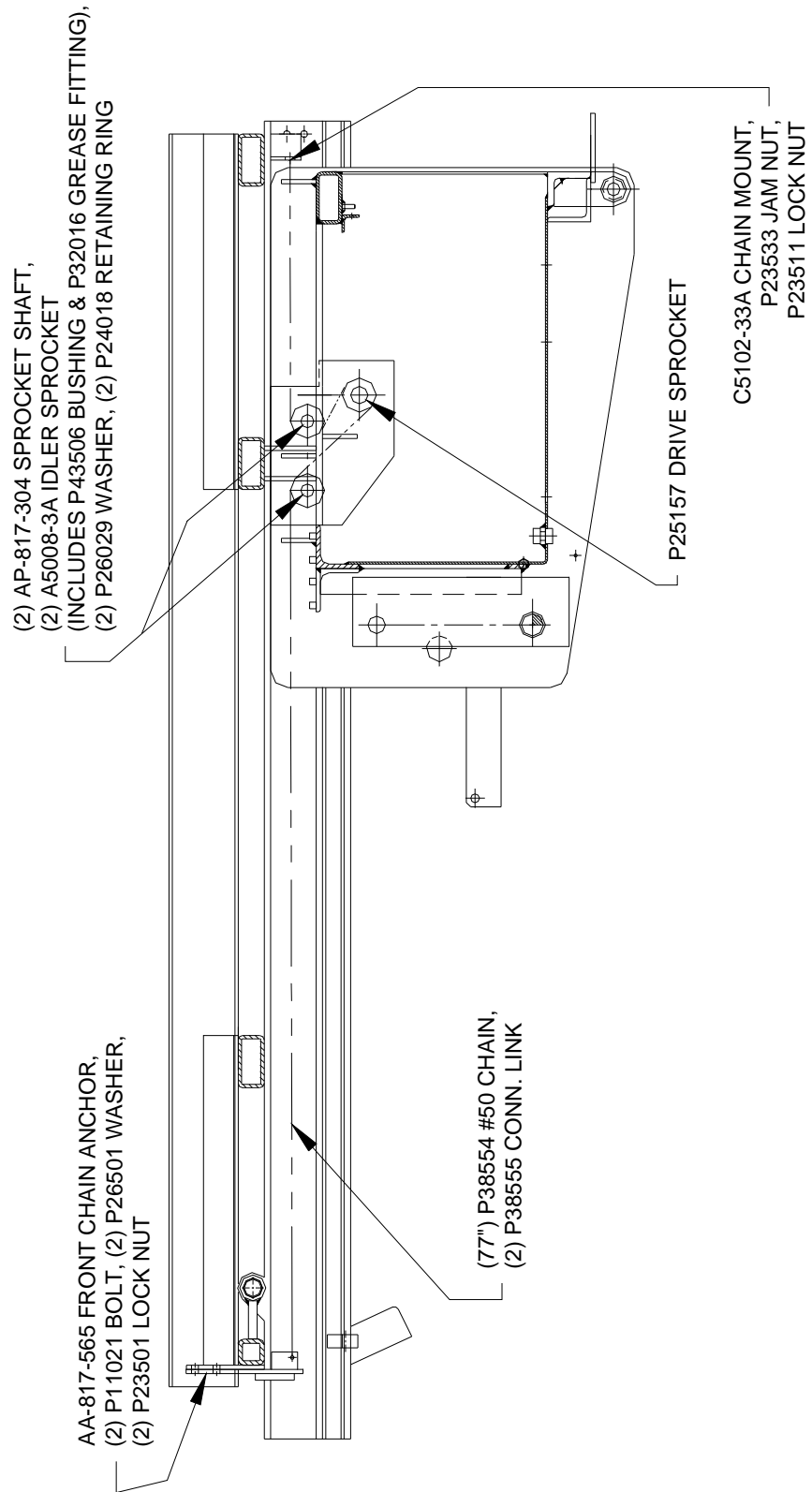

EMERGENCY HAND PUMP PARTS (Optional)

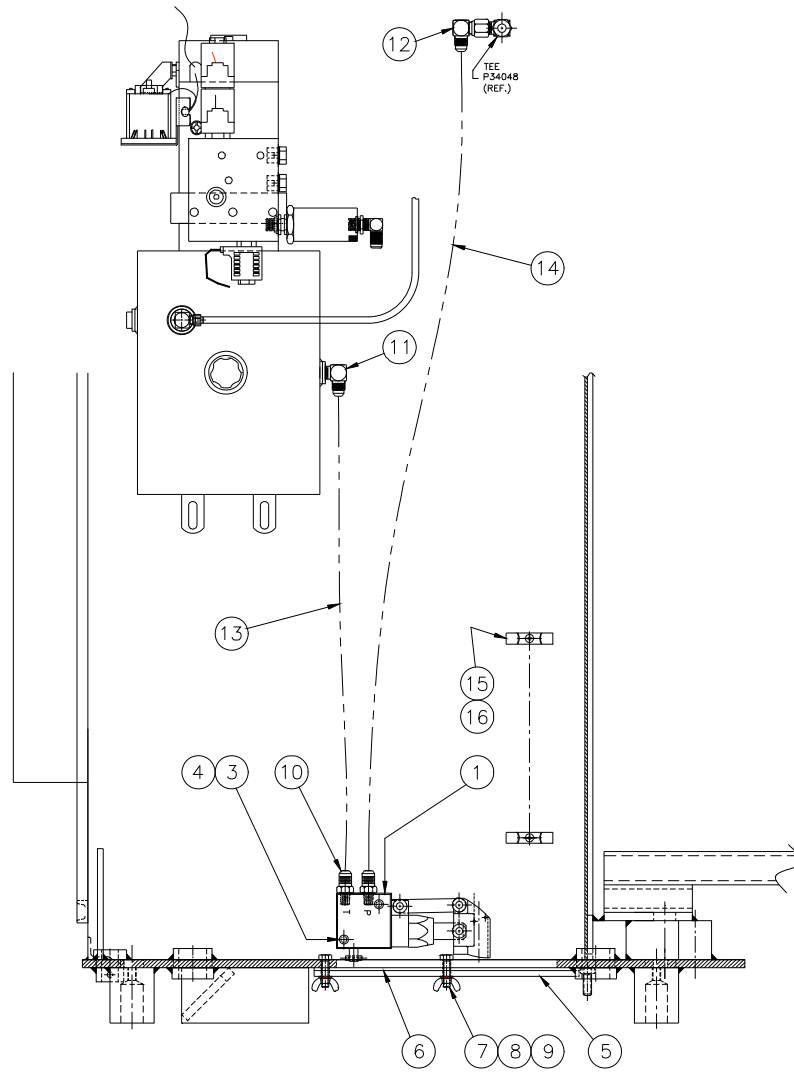

TOP VIEW

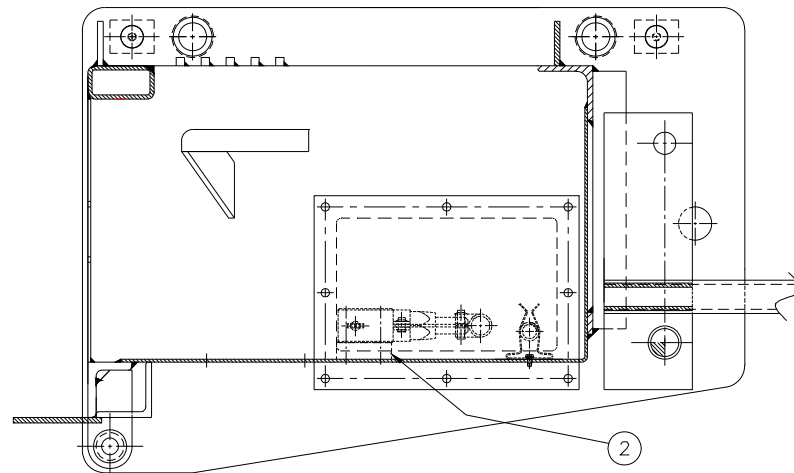

DRIVER'S SIDE VIEW

EMERGENCY HAND PUMP PARTS (Cont.)

REPLACEMENT PARTS

16	2	P17518	SELF-TAP SCREW		10-32 X 1/2 LG.		
15	2	P46192	TOOL HOLDER				
14	1	AT-501-354-037	HYD. HOSE ASSY.		JIC (F) - JIC (F)		
13	1	AT-501-354-021	HYD. HOSE ASSY.		JIC (F) - JIC (F)		
12	1	P34051	ELBOW		JIC (F) - JIC (M)		
11	1	P34005	ELBOW		3/8 NPT (M) - JIC (M)		
10	2	P34006	STR. ADAPTER		1/4 NPT (M) - JIC (M)		
9	8	P23545	WING NUT	18-8 SS	5/16-18		
8	8	P27027	LOCK WASHER		5/16		
7	8	P11059	HEX HD CAP SCREW	18-8 SS	5/16-18 X 1-1/4 LG.		
6	1	BP-817-708	GASKET - COVER PLATE				
5	1	BP-817-707	COVER PLATE - LPR				
4	2	P23502	LOCK NUT		1/4-20		
3	2	P16504	SOC HD CAP SCREW		1/4-20 X 2-3/4 LG.		
2	1	AP-658-355	SPACER, HAND PUMP				
1	1	P33902	HAND PUMP				
INDEX NO.	REQD.	PART NO.	PART NAME	MATL.	MATERIAL SIZE	REMARKS	WGT.

RETENTION RAMP PARTS

LPR4500RB

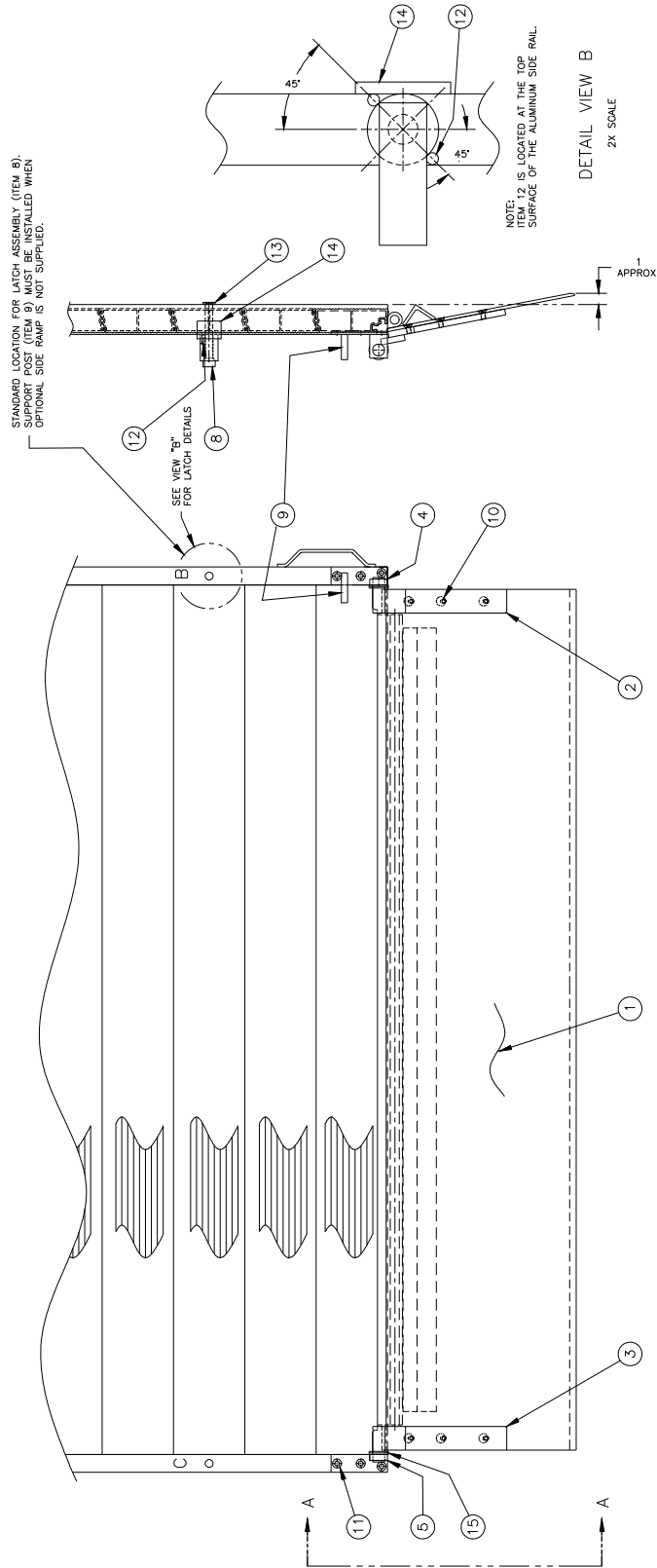

QTY	ITEM NO.	DESCRIPTION	MATERIAL	SIZE	REMARKS
15	4	P26020	MACH. BUSHING	1-5/8 OD X 1-1/32 ID X .135 THK.	
14	1	A023-002.000	STOP PLATE	AL RECT BAR 1/4 X 1-1/2 X 2 LG.	
13	1	AP-451-947	CAP		
12	2	S339-000.760	ROUND STOP	HR RND 1/4 DIA. X 3/4 LG.	
11	6	P18622	FLAT HEAD CAP SCREW	3/8-16 X 1 LG.	
10	6	P18625	FLAT HEAD CAP SCREW	3/8-16 X 7/8 LG.	
9	1	S150-002.125	SUPPORT POST	HR FLAT 1/2 X 2-1/2 X 2-1/8 LG.	
8	1	BA-817-650	LATCH ASSY		
7	2	AP-817-649	HOLD-UP TAB		
6	1	S752-072.500	HINGE BLOCK ASSY. - LH	CR RND 3/4 IN DIA X 72-1/2	
5	1	BA-817-648	HINGE BLOCK ASSY. - RH		
4	1	BA-817-647	HINGE ASSY. - LH		
3	1	BA-817-646	HINGE ASSY. - RH		
2	1	BA-817-645	RETENSION RAMP WELDM.		
1	1	CA-817-558	RETENSION RAMP WELDM.		

NOTE: APPLY THREAD LOCKING COMPOUND SUCH AS LOCTITE 242 OR 262 INDUSTRIES 121240 TO ITEMS 10 & 11 BEFORE ASSEMBLY.

NOTE: SLIP ITEM 6 THROUGH THE HINGE THEN WELD ITEM 7 ON BOTH ENDS. POSITION ITEM 7 ONTO ITEM 6 SUCH THAT THE RAMP LOCKS AS SHOWN. BE SURE ITEM 7 CAN SWIVEL DOWN SO THAT IT IS PARALLEL TO THE PLATFORM IN THE UNLOCKED POSITION.

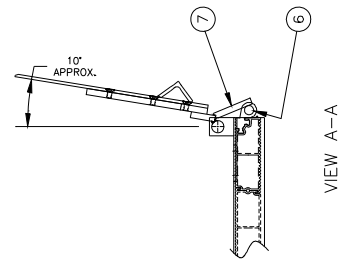

REF. ASSEMBLY DWG. DA-817-644

RETENTION RAMP PARTS

LPR45RBSR

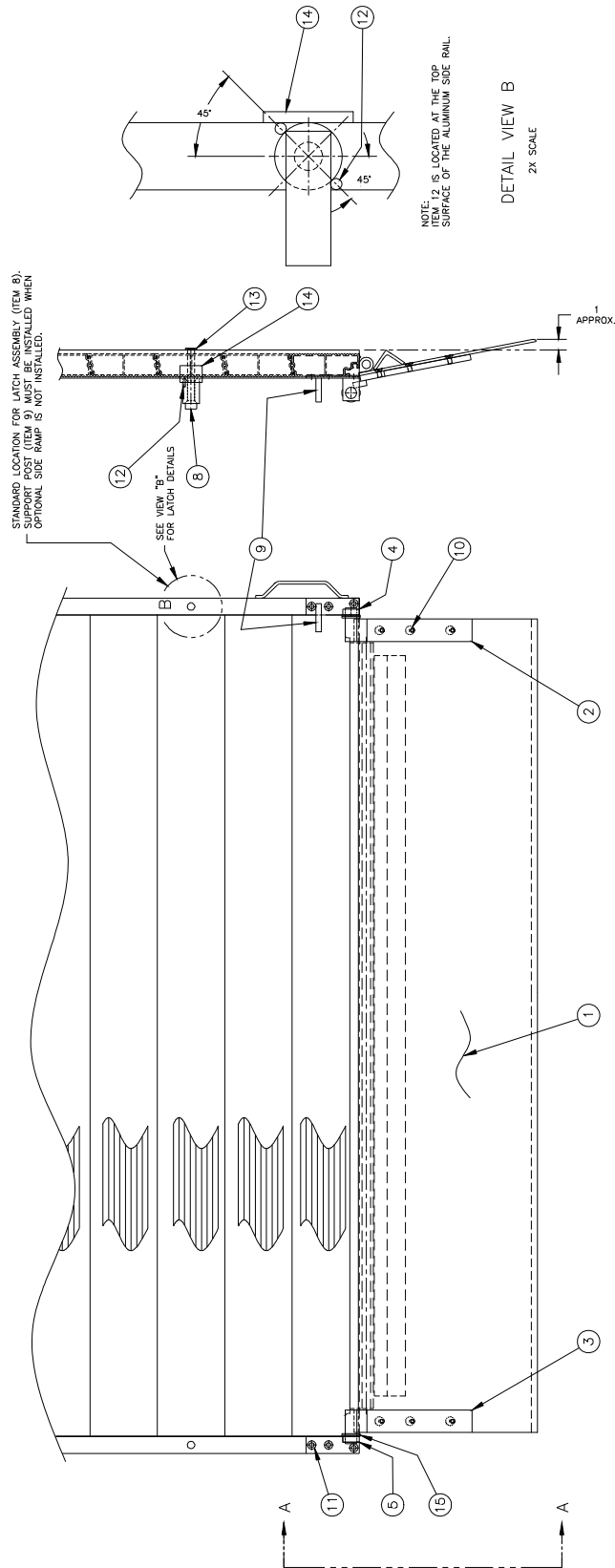

INDEX	QTY	PART NO.	PART NAME	MATL.	MATERIAL SIZE	REMARKS
15	4	P26020	MACH. BUSHING		1-5/8 OD X 1-1/32 ID X .135 THK.	
14	1	A023-002.000	STOP PLATE	AL RECT BHR	1/4 X 1-1/2 X 2 LG.	
13	1	AP-451-947	CAP			
12	2	S339-000.750	ROUND STOP	HR RND	1/4 DIA. X 3/4 LG.	
11	6	P18622	FLAT HEAD CAP SCREW		3/8-16 X 1 LG.	
10	6	P18625	FLAT HEAD CAP SCREW		3/8-16 X 7/8 LG.	
9	1	S160-002.125	SUPPORT POST	HR FLAT	1/2 X 2-1/2 X 2-1/8 LG.	
8	1	BA-817-660	LATCH ASSY			
7	2	AP-817-649	HOLD-UP TAB			
6	1	S752-072.500		CR RND	3/4 IN DIA X 72-1/2	
5	1	BA-817-701	HINGE BLOCK ASSY. - LH			
4	1	BA-817-700	HINGE BLOCK ASSY. - RH			
3	1	BA-817-711	HINGE ASSY. - LH			
2	1	BA-817-710	HINGE ASSY. - RH			
1	1	CA-817-558	RETENSION RAMP WELDM.			
INDEX/RECD:		PART NO.	PART NAME	MATL.	MATERIAL SIZE	REMARKS

NOTE: APPLY THE LOCKING COMPONENTS 121200 TO ITEMS 10 & 11 BEFORE ASSEMBLY.

NOTE: SLIDE ITEM 6 THROUGH THE HINGE THEN WELD ITEM 6 TO THE RAMP POSITION AS SHOWN. BE SURE ITEM 7 CAN SWIVEL DOWN SO THAT IT WILL TO THE PLATFORM IN THE UNLOCKED POSITION.

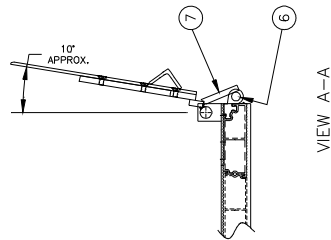

REF. ASSEMBLY DWG. DA-817-699

SIDE RAMP PARTS (Optional)

113LPRCURBSIDE1

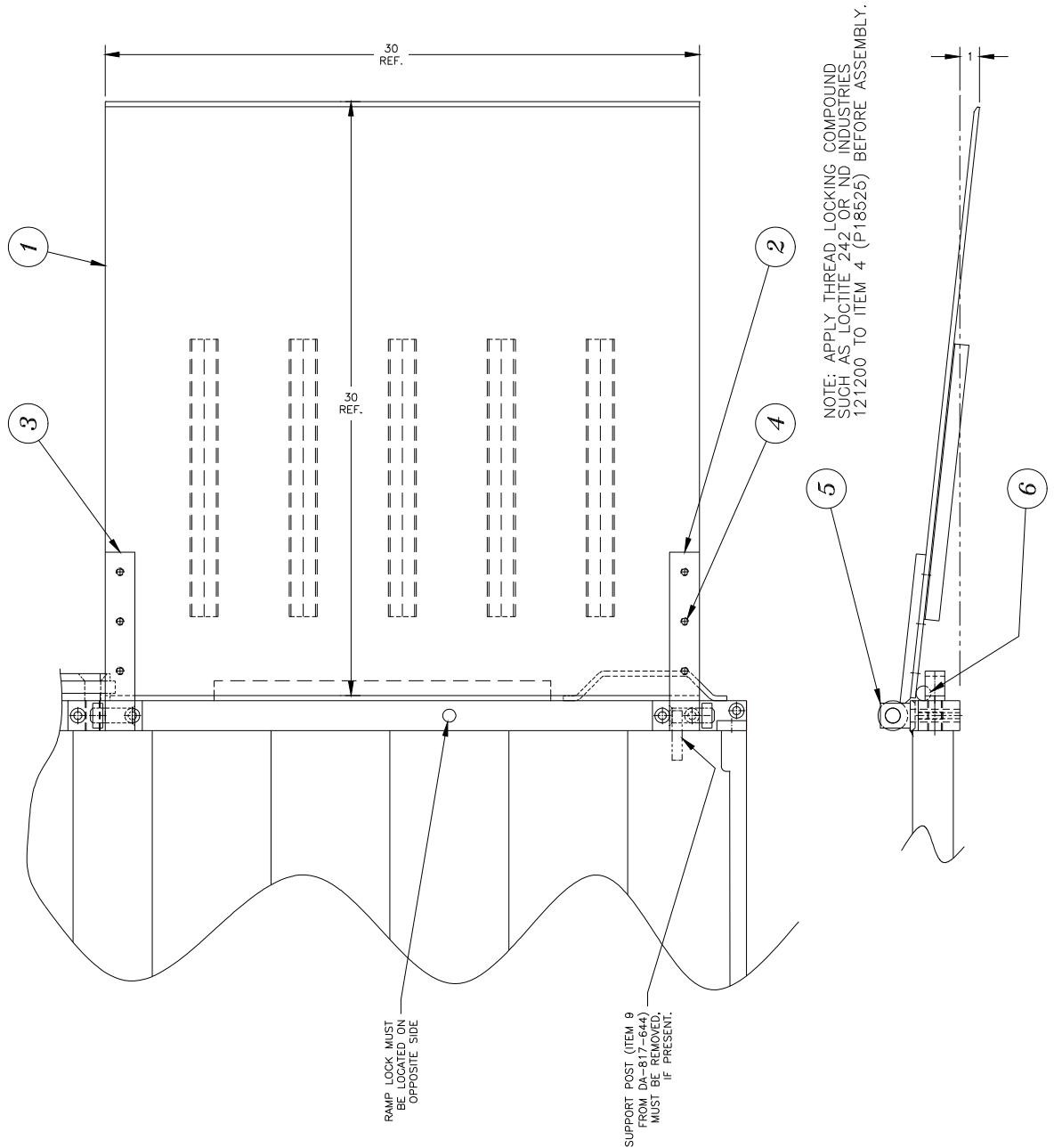

INDEX NO.	REQD.	PART NO.	PART NAME	MATL.	MATERIAL SIZE	REMARKS
6	1	A133-017.000	ALUM ROUND BAR	AL RND	3/4 IN DIA X 17 LG.	
5	2	AP-817-662	HINGE BLOCK			
4	6	P18525	FLAT HEAD SCREW	SS	3/8-16 X 7/8 LG.	
3	1	BA-817-661	HINGE ASSY - RH			
2	1	BA-817-660	HINGE ASSY - LH			
1	1	CA-817-690	SIDE RAMP DRILLED		30 X 30	

REF. ASSEMBLY DWG. CA-817-689

BASIC ELECTRICS – REPLACEMENT PARTS

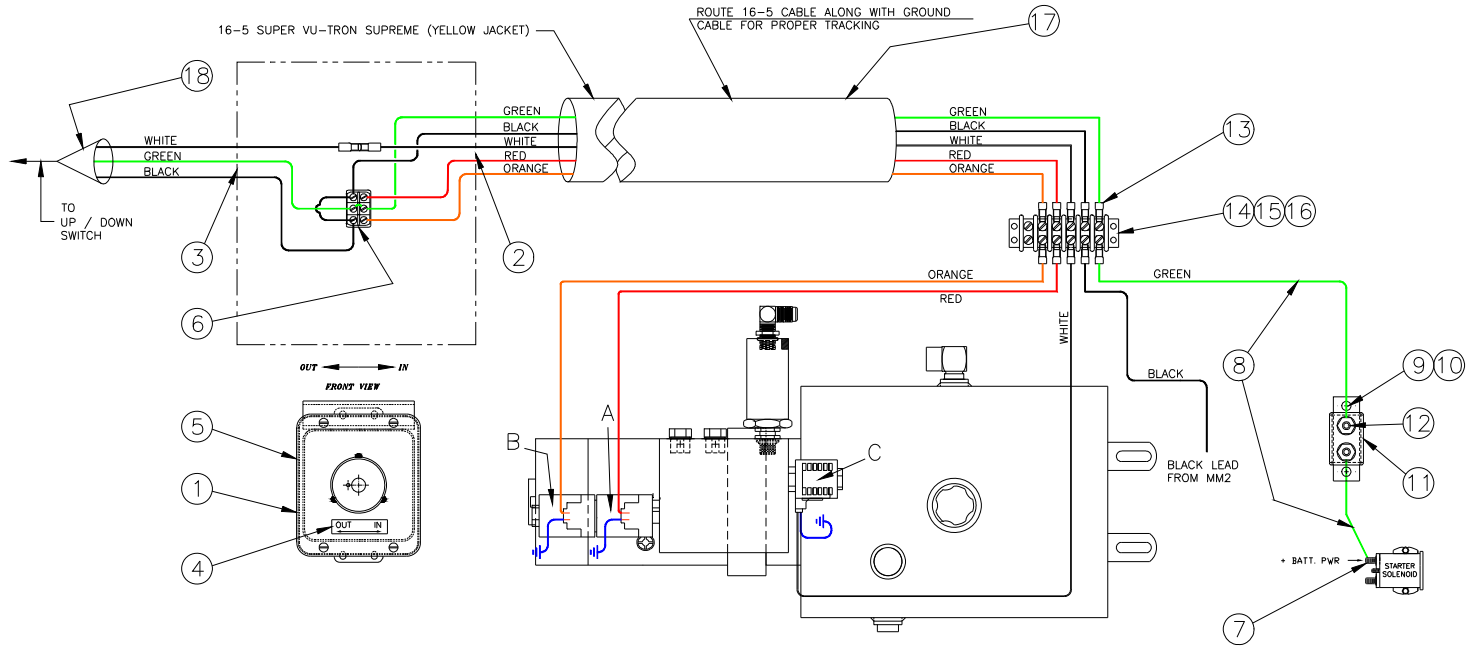

Index No.	Req'd	Part No.	Description	Comments
1	1	BA-551-585	SWITCH BOX ASSEMBLY - LPR	
2	1	P46445	CORD GRIP	FOR 16-5 CABLE
3	1	P46517	CORD GRIP	FOR 16-3 CABLE
4	1	AA-011-213	IN/OUT DECAL	
5	1	P55317	"DO NOT OPEN" DECAL	
6	1	AA-551-537	IN/OUT POTTED SWITCH ASSY	
7	1	P46235	LARGE RING TERMINAL	
8	2	P46301	WIRE - GREEN	12" LONG EA.
9	2	P19501	SCREW	10-24 X 1/2
10	2	P23504	NUT	
11	1	P46236	20 AMP CIRCUIT BREAKER	
12	2	P46507	SMALL RING TERMINAL	
13	10	P46319	FORK TERMINAL	
14	1	P46449	TERMINAL BLOCK	
15	2	P19510	SCREW	
16	2	P23535	LOCK NUT	
17	204"	P46748	16-5 CABLE (Flex)	Yellow Jacket
18	72"	P46186	16-3 CABLE	Black Jacket
	1	P55345	Electric / Hyd. Diagram (not shown)	w/ MM2 & temp. switch

STD. TOGGLE SWITCH REPLACEMENT PARTS

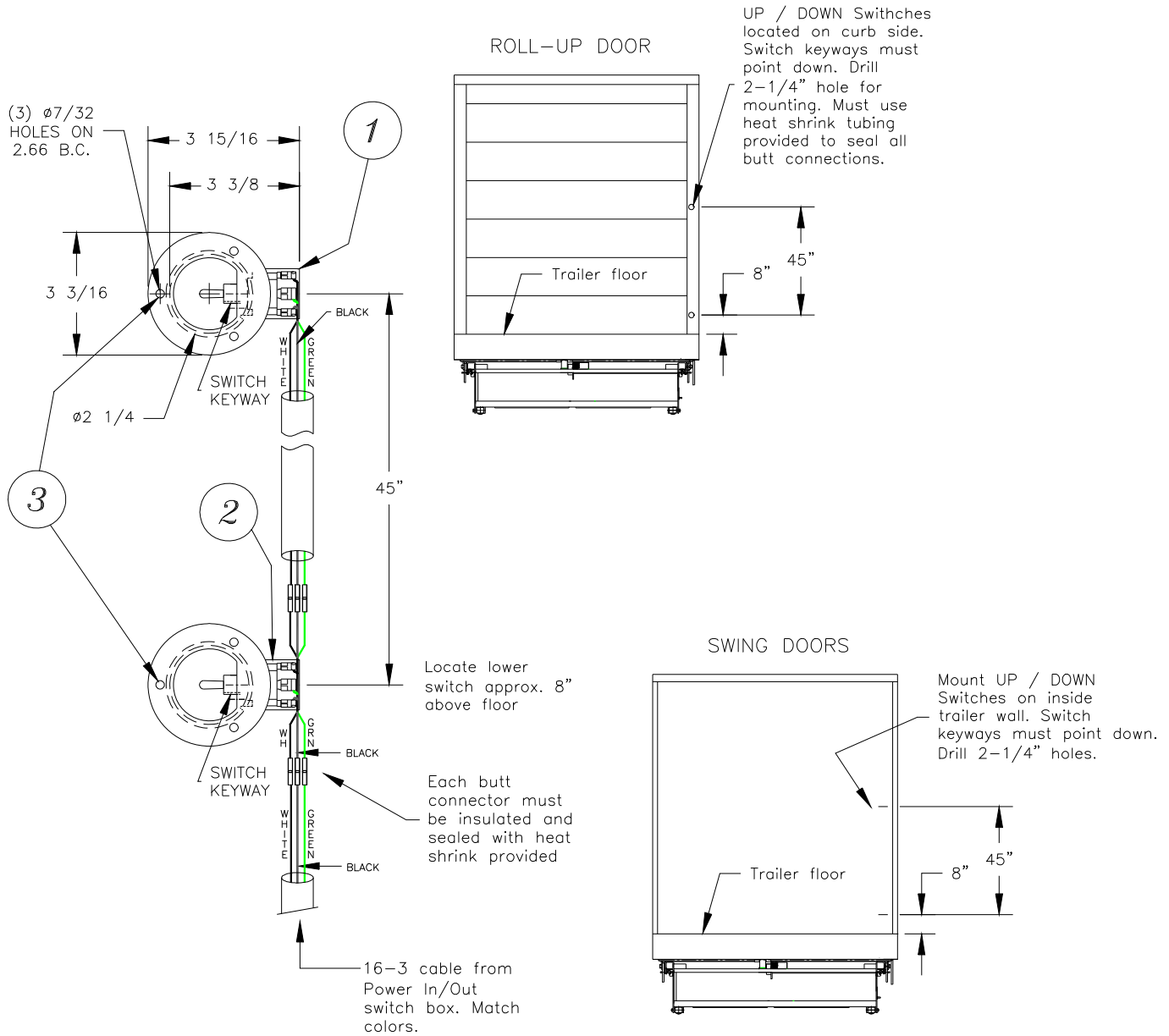

Index No.	Req'd	Part Number	Description	Comments
1	1	AA-551-538	TOP UP/DOWN SWITCH ASSY	POTTED w/ 16-3 cable
2	1	P46729	LOWER UP/DOWN SWITCH	POTTED
3	6	P17536	SHEET METAL SCREW	
4	4	P46250	LOOM CLAMP	NOT SHOWN
5	4	P17518	SELF TAPPING SCREW	NOT SHOWN

TOGGLE SWITCH W/ PUSHBUTTON REPLACEMENT PARTS

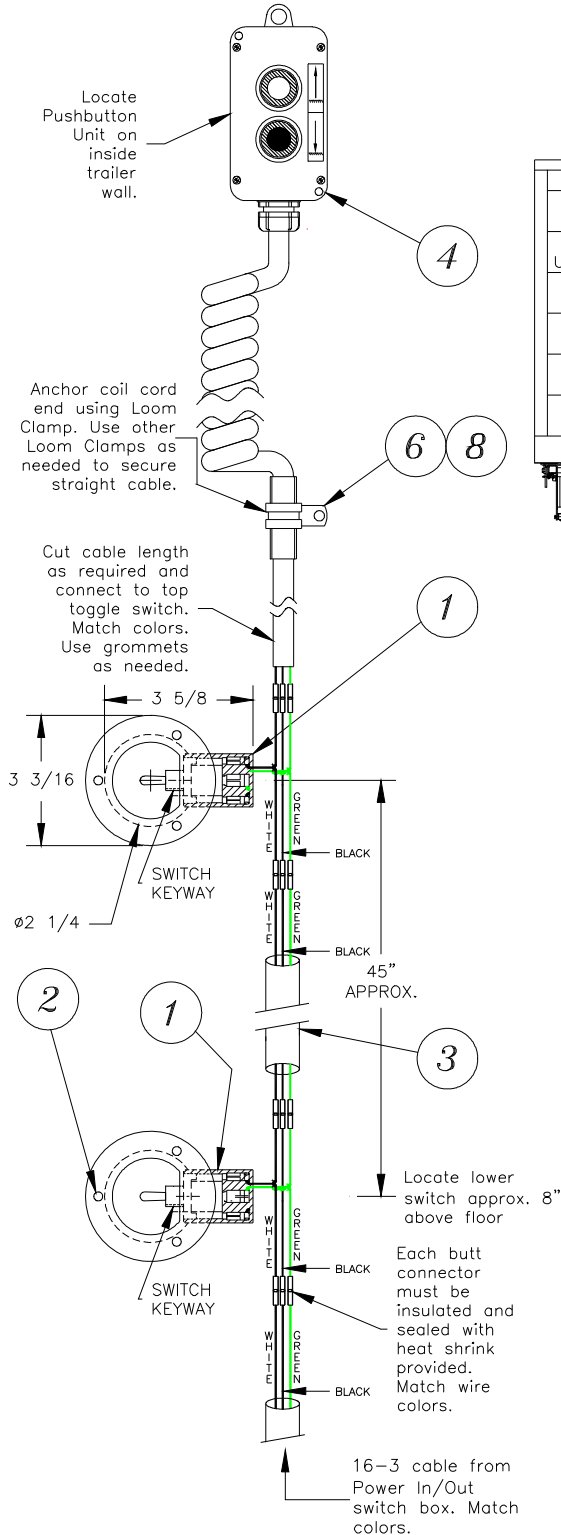

UP / DOWN Switches located on curb side. Switch keyways must point down. Drill 2-1/4" hole for mounting. Must use heat shrink tubing provided to seal all butt connections.

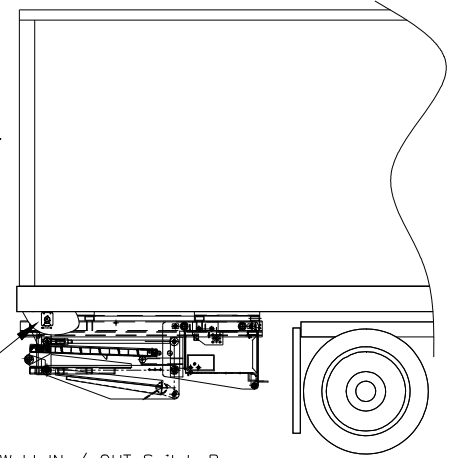
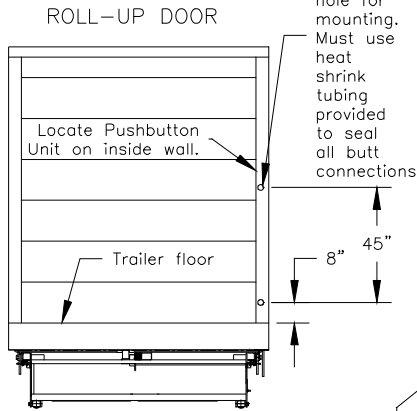

SWING DOORS

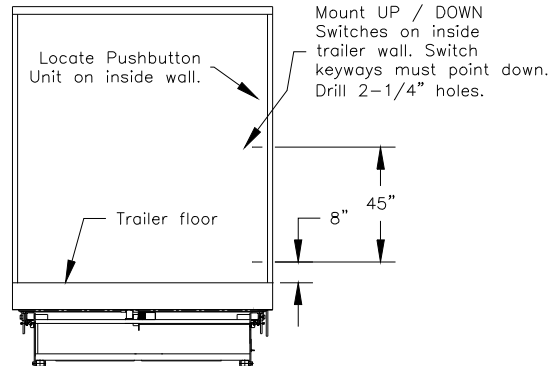

INDEX NO.	REQD.	PART NO.	PART NAME	MATL.	MATERIAL SIZE	REMARKS
8	7	P17518	SELF-TAP SCREW		10-32 X 1/2 LG.	
7	1	P49108	HOOK FOR WAPB			NOT SHOWN
6	7	P46450	LOOM CLAMP			
5	4	P25181	GROMMET			NOT SHOWN
4	1	BA-551-612	WAPB ASSY w/COIL CORD	(REF. P46636 PUSHBUTTON, P46008 COIL CORD)		
3	1	P46186	16-3 CABLE		1 PC. - 42" LG.	
2	6	P17536	SHEET METAL SCREW		10-16 X 3/4 LG.	
1	2	P46729	TLS SWITCH ASSY.			

INSTALLATION OF SAFETY DECALS

Leyman Manufacturing will replace safety stickers at any time **FREE OF CHARGE**.

P55438	Operating Instructions	Loc. A (Qty. 1)
P55157	Urgent Warning....	Loc. A (Qty. 1)
P55294	CAUTION Do Not Stand....	Loc. A (Qty. 1)
P55193	Maximum Capacity	Loc. A (Qty. 1)
AP-011-213	IN – OUT Decal	Loc. B (Qty. 1)
P55347	CAUTION Pinch Point	Loc. C (Qty. 2)
P55157	Urgent Warning....	Loc. D (Qty. 1)
P55221	UP / DOWN Switch	Loc. D (Qty. 2)
P55138	Keep Feet....	Loc. E (Qty. 1)
P55441	Primary Platform at Stored....	Loc. E (Qty. 1)

