



**[LPR]** TRAILER REAR LIFT

**LIFTING CAPACITY 4,500 lbs.**

- Installs without cutting up to 10" Floor Heights: \*Laden/58" Unladen

\*Floor height is a function of trailer construction. Contact Leyman for correct Laden height for your trailer.

LPR STANDARD FEATURES	BENEFITS
True Level Ride Lift Gate	Provides a Safer Working Environment for Driver and Freight
Power In and Out with Stainless Steel Chain	Designed to Reduce Road Calls
Adjustable Guides (In/Out – Side/Side Functions)	Ensures Optimal Fit and Performance
Pressure Compensated Flow Control	Steady Hydraulic Pressure for Smooth Operation
Greaseless Bushings and Rollers	Reduces Maintenance Costs
Flashing Safety Lights	Increases Visibility
Power Pack Enclosure	Houses Pump, Motor, and Room for Up to Four (4) Batteries
Primary Platform at Stored Position Creates DOT Bumper	Meets D.O.T. Requirements For U.S. and Canada
Gravity Down	Reduces Power Usage and Motor Wear
Marine Potted Switches	Watertight Switches – Reduces Electrical Failure
Spring Assisted Opening and Closing	Ease of Use and Reduces Physical Effort to Operate
Maintenance Minder2	Measures and Records Lift Gate Operating Data

# LEYMAN

## LIFT GATES

DELIVERS DEPENDABILITY

SINCE 1940

# LPR Hide-A-Way® Trailer Rear Gate

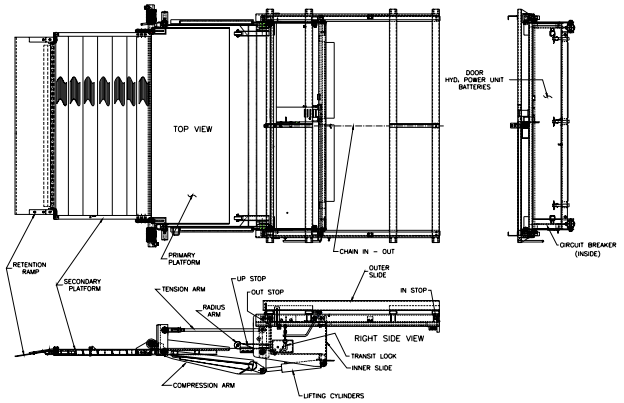
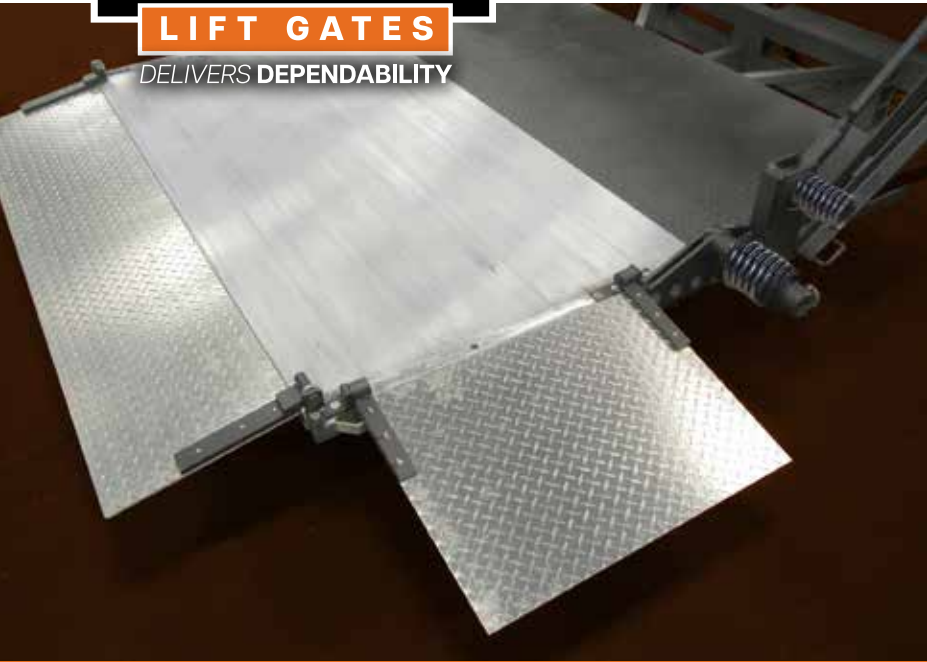

### LPR Technical Specs

Model Number	Lifting Capacity	Platform Size	Main Platform	Secondary Platform	Ramp	Vehicle Width	Approx. Weight
LPR 4500	4,500 lbs.	80" W x 72" D	32" D Steel	40" D Aluminum	16" Retention	102"	1,825 lbs.

### AVAILABLE OPTIONS

OPTION #	DESCRIPTION
103	Handheld Remote, Plugs into Receptacle
111	Additional Circuit Breaker for Supply Line
113LPRCURBSIDE	28" W x 20" D Aluminum Retention Ramp Curbside
133	Conversion Kit For Mounting to Aluminum Cross Members
134	Mud Flap
154	Reflecting Tape
184	Emergency Hand Pump
GV	Galvanized (Full Gate)
P46622	AGM Battery

### POWER KITS

OPTION #	OPTION DESCRIPTION
257NG-70	Power Kit: 70' "2" Gauge Cable – Dual Pole with Combo Box (Dual/Single Pole Receptacles)
269-2B	Battery Hold-Down Kit - 2 Batteries for 42, 48, 60, 72, 80 Gate Width
269-3B	Battery Hold-Down Kit - 3 Batteries for 60, 72, 80 Gate Width
269-4B	Battery Hold-Down Kit - 4 Batteries for 72, 80 Gate Width